

TOP VIEW

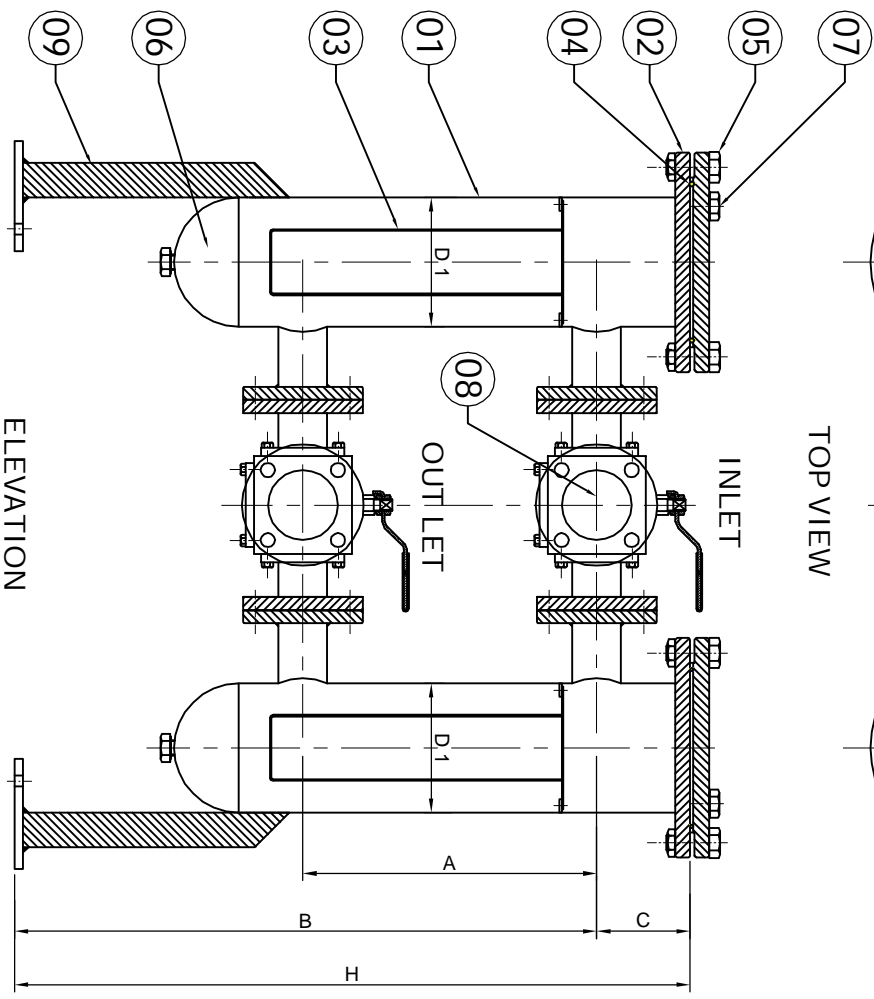

ELEVATION

SIZE		CLASS - 150				
MM.	INCH	A	B	C	D1	H
40	1.1/2"	450	150	300	OD 4" PIPE	900
50	2"	450	150	300	OD 4" PIPE	900
80	3"	500	175	375	OD 5" PIPE	1000
100	4"	600	200	400	OD 6" PIPE	1200
125	5"	675	225	500	OD 8" PIPE	1400
150	6"	750	250	500	OD 8" PIPE	1500
200	8"	835	315	750	OD 10" PIPE	1900

SR. NO.	PARTS NAME	MAT.
01.	BODY	IS 3589
02.	TOP COVER	IS 2062
03.	SCREEN	SS 304
04.	GASKET	NITRILE
05.	COVER BOLT & NUT	CARBON STEEL
06.	DRAIN PLUG	ASTM A105
07.	VENT PLUG	ASTM A105
08.	3 WAY BALL VALVE	ASTM A 216 Gr.WCB
09.	LEG SUPPORT	M.S.

TECHNICAL DATA	
DESIGN & MANUFACTURING STD.	ASME B 16.34
END CONNECTIONS :	FLANGED AS PER ASME B 16.5 - 150#
FACE TO FACE :	AS PER ASME B 16.10

HYD. TEST PRESSURE	BODY
	10 KG/CM2

DRN. : B.M.P	 <p>NORFLOW CONTROLS Industrial Valves</p>
CHK. : V.G.P	
APRD. : S.K.P	
DATE:01.04.19	
SCALE : NTS	<p>M.S. FABRICATED "BASKET" TYPE STRAINERS -DUPEX</p>
DRG NO. : NC/STR/DP/150/40 - 200	